

S = STRAIGHT

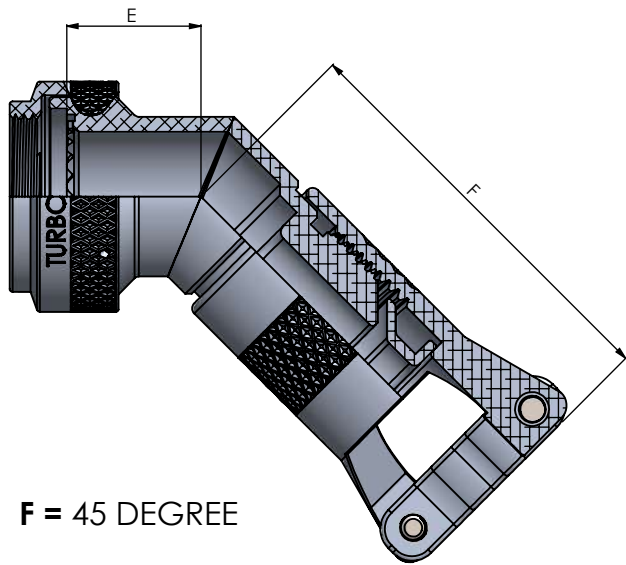

F = 45 DEGREE

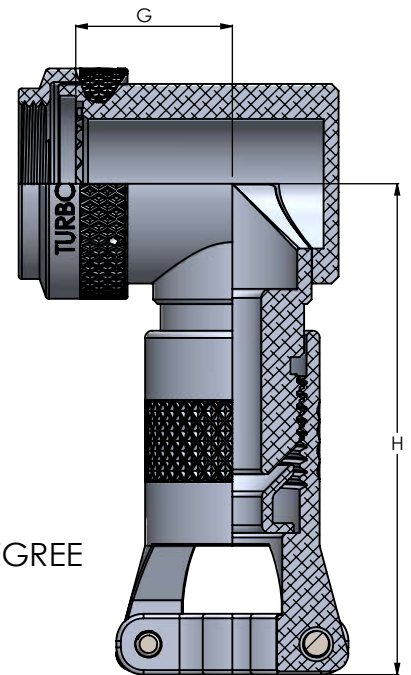

N = 90 DEGREE

### ORDERING INFORMATION

**TB 110-04 - H 3 F VO - 13 04 - L - 6**

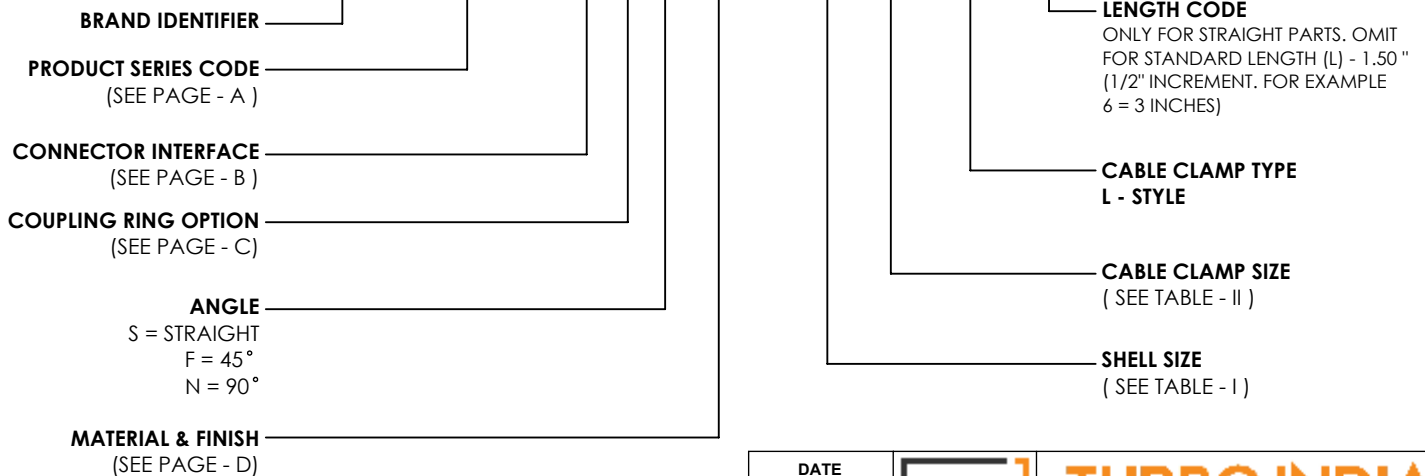

**\*\* CUSTOMIZATION POSSIBLE**

		DATE
DRAWN :	VN	28-12-2020
CHECKED :	AD	28-12-2020
APPROVED :	MR	28-12-2020



**TURBO INDIA**  
INTERCONNECT SOLUTIONS LLP  
#114, 1st Floor, P C Industrial Estate, Kamakshipalya,  
Magadi Rd, Bangalore 560 079, Karnataka, India

THIS DRAWING IS COPYRIGHT AND THE PROPERTY OF TURBO INDIA INTERCONNECT SOLUTIONS. IT MUST NOT BE COPIED, USED FOR MANUFACTURE OR OTHERWISE DISCLOSED WITHOUT PRIOR WRITTEN CONSENT OF THE COMPANY.

UNLESS OTHERWISE SPECIFIED : ALL DIMENSIONS IN MILLIMETRES  
GENERAL TOL: LINEAR : ± 0.10MM  
ANGULAR : ± 2°

MATERIAL :	---	REV.No 01
WEIGHT :	---	
ASSEMBLY USED ON:		
---		

DESCRIPTION :	
CABLE CLAMP ADAPTER - NON ENVIRONMENTAL , SCREENED	
PART NUMBER / SERIES:	PAGE:NO
SERIES 110 -04	34

TABLE - I SHELL SIZE							
CONNECTOR DESIGNATOR			RING DIMENSION	ELBOW DIMENSIONS			
A & B	F & D	H	Ø C MAX	E MAX	F MAX	G MAX	H MAX
08	08	09	22.48	11.68	80.01	17.53	87.88
10	10	11	25.65	13.21	81.53	19.81	90.93
12	12	13	28.83	14.73	83.06	20.32	91.44
14	14	15	32.00	16.51	85.34	22.35	93.22
16	16	17	35.18	18.80	88.14	23.62	95.50
18	18	19	38.35	23.62	92.96	25.65	99.82
20	20	21	41.53	23.62	92.96	26.92	99.82
22	22	23	44.70	25.91	96.77	29.72	102.62
24	24	25	47.88	25.91	96.77	29.97	102.62

TABLE- II CABLE CLAMP SIZE				
DASH NO	Ø M MIN	Ø M MAX	K MAX	Z MAX
01	1.6	3.2	19.8	31.75
02	3.2	6.4	24.6	31.75
04	6.4	9.5	26.6	31.75
06	9.5	12.7	29.4	31.75
08	12.7	15.9	30.9	33.27
10	15.9	19.1	34.1	35.05
12	19.1	22.2	37.3	38.10
14	22.2	25.4	40.5	41.40
16	25.4	28.6	43.6	41.40
18	28.6	31.8	46.8	41.40

1. WHEN MAXIMUM CABLE ENTRY IS EXCEEDED , STYLE-2 WILL BE SUPPLIED . IN THAT CONDITION, DIMENSIONS E,F,G AND H WILL NOT APPLY.
2. FOR ANY KIND OF CUSTOMISATION/SHELL SIZE ON THIS BACKSHELL, FOR TERMINATION BANDS AND OTHER ACCESSORIES REACHOUT TO US ON [sales@turboindia.co.in](mailto:sales@turboindia.co.in)

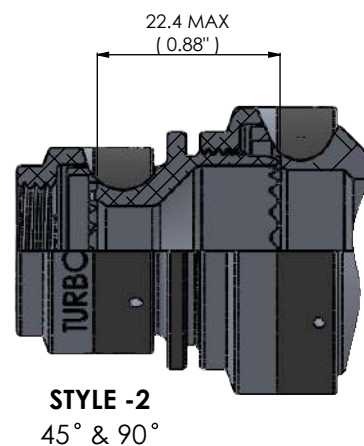
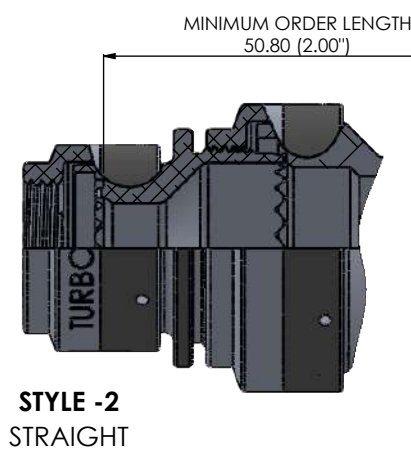

		DATE
DRAWN :	VN	28-12-2020
CHECKED :	AD	28-12-2020
APPROVED :	MR	28-12-2020



**TURBO INDIA**  
 INTERCONNECT SOLUTIONS LLP  
 #114, 1st Floor, P C Industrial Estate, Kamakshipalya,  
 Magadi Rd, Bangalore 560 079, Karnataka, India

THIS DRAWING IS COPYRIGHT AND THE PROPERTY OF TURBO INDIA INTERCONNECT SOLUTIONS. IT MUST NOT BE COPIED, USED FOR MANUFACTURE OR OTHERWISE DISCLOSED WITHOUT PRIOR WRITTEN CONSENT OF THE COMPANY.

UNLESS OTHERWISE SPECIFIED :  
 ALL DIMENSIONS IN MILLIMETRES  
 GENERAL TOL:  
 LINEAR : ± 0.10MM  
 ANGULAR : ± 2°

MATERIAL :	---	REV.No 01
WEIGHT :	---	
ASSEMBLY USED ON:		
---		

DESCRIPTION : CABLE CLAMP ADAPTER - NON ENVIRONMENTAL , SCREENED	
PART NUMBER / SERIES: SERIES 110 -04	PAGE:NO 35