

S = STRAIGHT

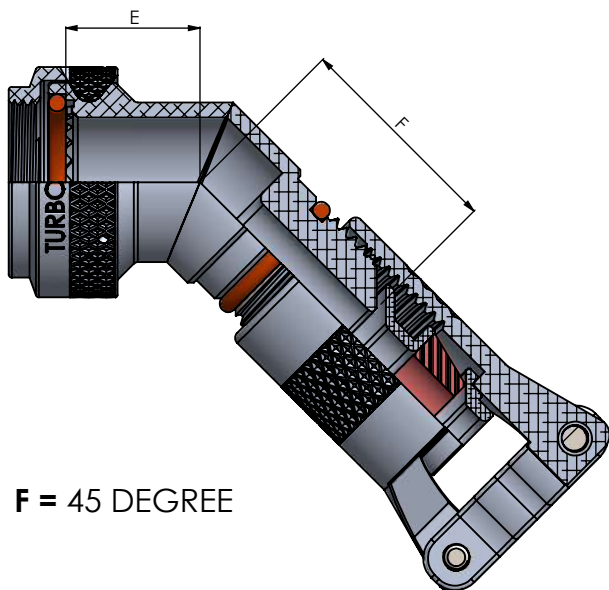

F = 45 DEGREE

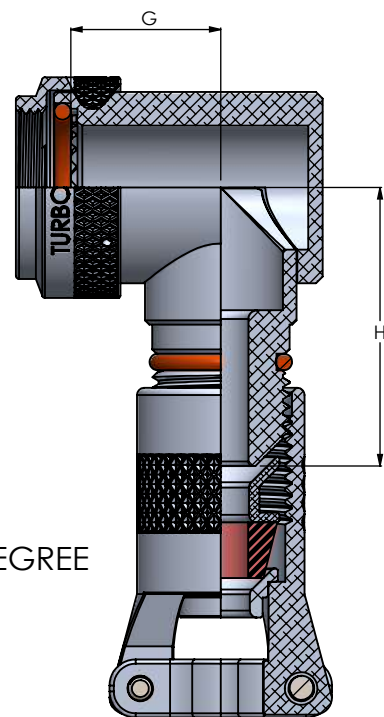

N = 90 DEGREE

ORDERING INFORMATION

TB 110-03 - H 3 F VO - 13 04 - L - 6

BRAND IDENTIFIER
PRODUCT SERIES CODE
 (SEE PAGE - A)
CONNECTOR INTERFACE
 (SEE PAGE - B)
COUPLING RING OPTION
 (SEE PAGE - C)
ANGLE
 S = STRAIGHT
 F = 45°
 N = 90°
MATERIAL & FINISH
 (SEE PAGE - D)

LENGTH CODE
 ONLY FOR STRAIGHT PARTS. OMIT
 FOR STANDARD LENGTH (L) - 1.75"
 (1/2" INCREMENT. FOR EXAMPLE
 6 = 3 INCHES)
CABLE CLAMP TYPE
 L - STYLE
CABLE CLAMP SIZE
 (SEE TABLE - II)
SHELL SIZE
 (SEE TABLE - I)

** CUSTOMIZATION POSSIBLE

		DATE
DRAWN :	VN	28-12-2020
CHECKED :	AD	28-12-2020
APPROVED :	MR	28-12-2020



TURBO INDIA

INTERCONNECT SOLUTIONS LLP
 #114, 1st Floor, P C Industrial Estate, Kamakshipalya,
 Magadi Rd, Bangalore 560 079, Karnataka, India

THIS DRAWING IS COPYRIGHT AND THE PROPERTY OF TURBO INDIA INTERCONNECT SOLUTIONS. IT MUST NOT BE COPIED, USED FOR MANUFACTURE OR OTHERWISE DISCLOSED WITHOUT PRIOR WRITTEN CONSENT OF THE COMPANY.

UNLESS OTHERWISE SPECIFIED : ALL DIMENSIONS IN MILLIMETRES
 GENERAL TOL:
 LINEAR : ± 0.10MM
 ANGULAR : ± 2°

MATERIAL :	---	REV.No 01
WEIGHT :	---	
ASSEMBLY USED ON:		

DESCRIPTION :	
SUBMERSIBLE CABLE CLAMP ADAPTER - ENVIRONMENTAL , SCREENED	
PART NUMBER / SERIES:	PAGE:NO
SERIES 110 -03	32

TABLE - I SHELL SIZE							
CONNECTOR DESIGNATOR			RING DIMENSION	ELBOW DIMENSIONS			
A & B	F & D	H	Ø C MAX	E MAX	F MAX	G MAX	H MAX
08	08	09	22.48	21.00	48.20	23.80	44.90
10	10	11	25.65	21.60	49.80	25.30	45.90
12	12	13	28.83	22.20	51.30	26.90	45.20
14	14	15	32.00	22.70	53.60	28.10	45.20
16	16	17	35.18	23.40	56.40	29.70	46.20
18	18	19	38.35	23.80	61.20	30.70	49.30
20	20	21	41.53	24.40	61.20	32.20	47.50
22	22	23	44.70	25.10	65.00	33.70	49.00
24	24	25	47.88	25.70	65.00	35.20	47.20

TABLE- II CABLE CLAMP SIZE				
DASH NO	Ø M MIN	Ø M MAX	K MAX	Z MAX
01	1.6	3.2	19.8	29.5
02	3.2	6.3	24.6	29.5
04	6.3	9.5	26.6	29.5
06	9.5	12.7	29.4	29.5
08	12.7	15.8	30.9	29.5
10	15.8	19.0	34.1	29.5
12	19.0	22.2	37.3	29.5
14	22.2	25.4	40.5	29.5
16	25.4	28.6	43.6	29.5
18	28.6	31.8	46.8	29.5

1. WHEN MAXIMUM CABLE ENTRY IS EXCEEDED , STYLE-2 WILL BE SUPPLIED . IN THAT CONDITION, DIMENSIONS E,F,G AND H WILL NOT APPLY.
2. FOR ANY KIND OF CUSTOMISATION/SHELL SIZE ON THIS BACKSHELL, FOR TERMINATION BANDS AND OTHER ACCESSORIES REACHOUT TO US ON sales@turboindia.co.in

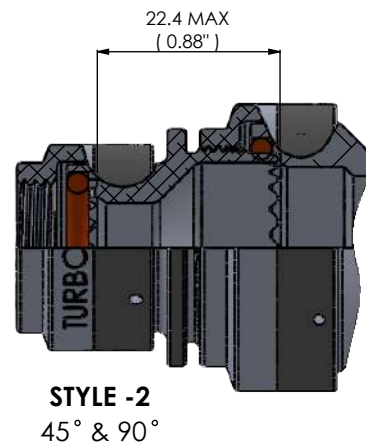
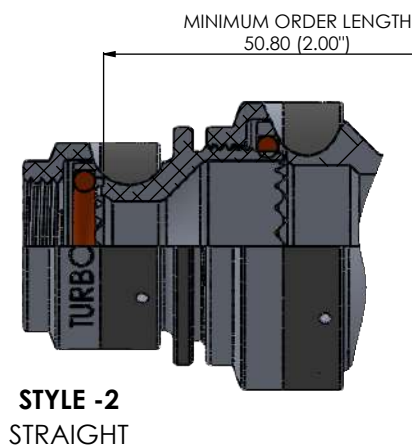

THIS DRAWING IS COPYRIGHT AND THE PROPERTY OF TURBO INDIA INTERCONNECT SOLUTIONS. IT MUST NOT BE COPIED, USED FOR MANUFACTURE OR OTHERWISE DISCLOSED WITHOUT PRIOR WRITTEN CONSENT OF THE COMPANY.	UNLESS OTHERWISE SPECIFIED : ALL DIMENSIONS IN MILLIMETRES GENERAL TOL: LINEAR : ± 0.10MM ANGULAR : ± 2°	DRAWN :	VN	DATE	28-12-2020	 TURBO INDIA INTERCONNECT SOLUTIONS LLP #114, 1st Floor, P C Industrial Estate, Kamakshipalya, Magadi Rd, Bangalore 560 079, Karnataka, India
		CHECKED :	AD	DATE	28-12-2020	
		APPROVED :	MR	DATE	28-12-2020	
		MATERIAL :	---	REV.No	01	
		WEIGHT :	---	DESCRIPTION :	SUBMERSIBLE CABLE CLAMP ADAPTER - ENVIRONMENTAL , SCREENED	
		ASSEMBLY USED ON:			PART NUMBER / SERIES:	PAGE:NO
		---			SERIES 110 -03	33